

# KML-250/351M\_H

Item # \_\_\_\_\_

Project: \_\_\_\_\_

Qty: \_\_\_\_\_

\*AutoCad available on KCL

## LOW PROFILE MODULAR CRESCENT CUBER

KML-250/351M\_H

6/11

Item # 13224

### CUBER DIMENSIONS W x D x H

**KML-250/351M\_H**  
30 x 27<sup>3/8</sup> x 22

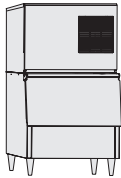

B-250



B-500



DB-200

Also available on  
Bins:  
B-700PF/SF  
B-800PF/SF  
B-900PF/SF

Large Bins:  
B-1150SS  
B-1300SS  
B-1500SS  
B-1650SS



### KML-250MAH

Air-Cooled  
Shown on an optional  
B-500

### KML-250MWH

Water-Cooled

### KML-351MAH

Air-Cooled

### KML-351MWH

Water-Cooled



### KML-250M\_H

- Up to 314 lbs. of ice production per 24 hours

### KML-351M\_H

- Up to 350 lbs. of ice production per 24 hours

### KML-250M\_H & KML-351M\_H

- Durable stainless steel exterior
- Individual crescent cube
- Protected by *H-GUARD Plus* Antimicrobial Agent 
- CycleSaver® Design 
- EverCheck® alert system 
- Stainless steel evaporator
- Removable air filters (Air-cooled models only)
- Lower height for restricted areas (stairwells, low ceilings)
- R-404A Refrigerant

\* The KML-351MAH is ENERGY STAR qualified.

### Warranty

Valid in United States, Canada, Puerto Rico, & U.S. Territories. Contact factory for warranty in other countries.

**Three Year** - Parts & Labor on entire machine.

**Five Year** - Parts & Labor on: Evaporator.

**Five Year** - Parts on: Compressor, air-cooled condenser coil.



1507001-1 5/31/00E



# Hoshizaki

## KML-250/351M\_H LOW PROFILE MODULAR CRESCENT CUBER

**DIMENSIONS**  
W x D x H  
**KML-250/351M\_H**  
30 x 27<sup>3/8</sup> x 22

- Air-cooled
- Water-cooled

### AIR-COOLED - KML-250/KML-351

Water Temp° F.	50°	70°	90°
Air Temp° F. 70°	307 / 333	287 / 318	267 / 288
80°	292 / 322	260 / 298	245 / 262
90°	287 / 318	<b>238 / 282</b>	220 / 248

### WATER-COOLED - KML-250/KML-351

Water Temp° F.	50°	70°	90°
Air Temp° F. 70°	314 / 345	306 / 340	290 / 318
80°	308 / 341	296 / 333	277 / 303
90°	306 / 340	<b>284 / 327</b>	269 / 300

### UTILITY CONSUMPTION

Model Number	Ice Production Per Cycle		KWH per 100 LBS. 90/70	Potable Water Gal. per 100 lbs.	Condenser Water Gal. per 100 lbs.
	Lbs.	Cubes			
KML-250MAH	6.6	360	8.2	35.2	N/A
KML-250MWH	6.6	360	6.2	43.7	123
KML-351MAH	7.3	360	6.4	20.3	N/A
KML-351MWH	7.1	360	5.3	20.4	131

### SPECIFICATIONS

Model Number	Condenser	Amperage	Min. Circuit Ampacity	Shipping Weight
KML-250MAH	Air-Cooled	8.2	20	185 lbs.
KML-250MWH	Water-Cooled	7.5	20	185 lbs.
KML-351MAH	Air-Cooled	13.2	20	185 lbs.
KML-351MWH	Water-Cooled	7.5	20	185 lbs.

### STORAGE BINS

Model Number	Application Capacity	ARI-Rated Capacity
B-250	250 lbs.	230 lbs.
B-500	500 lbs.	360 lbs.
B-700	700 lbs.	550 lbs.
B-800	800 lbs.	600 lbs.
B-900	900 lbs.	660 lbs.
B-1150	1150 lbs.	N/A
B-1300	1275 lbs.	N/A
B-1500	1490 lbs.	N/A
B-1650	1605 lbs.	N/A

### ELECTRICAL & PLUMBING/KML-250/351M\_H

- 115/60/1
- 20 amp Max Fuse/HACR Breaker Size
- 1/2" OD copper or equivalent independent potable water supply
- 3/4" FPT independent drain connection



© HOSHIZAKI AMERICA, INC.  
618 Hwy. 74 S., Peachtree City, GA 30269

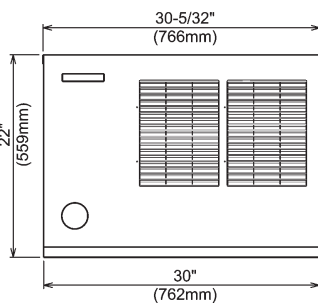

FRONT VIEW

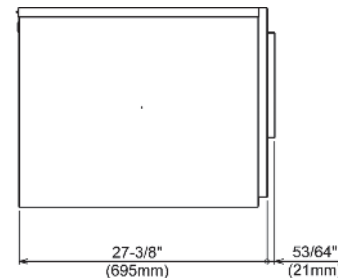

SIDE VIEW

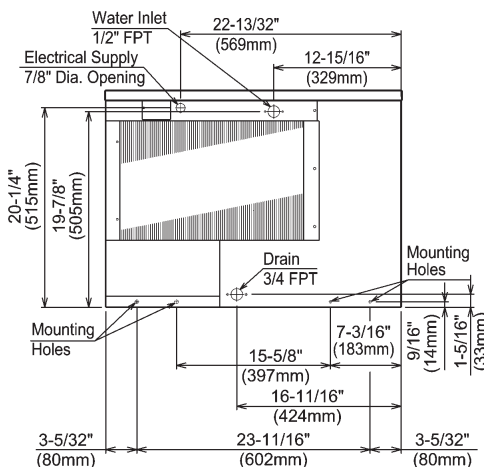

AIR-COOLED UNIT

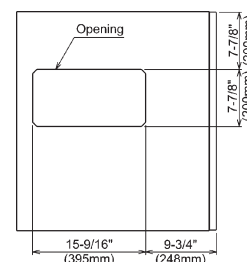

ICE DROP ZONE

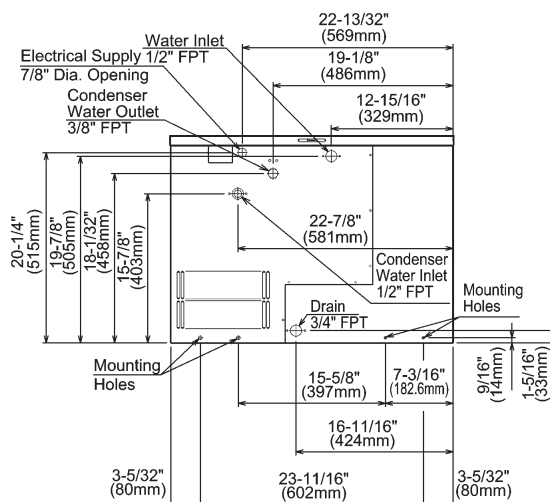

WATER-COOLED UNIT

### OPERATING LIMITS

- Ambient Temp Range 45 - 100°F
- Water Temp Range 45 - 90°F
- Water Pressure 10 - 113psig
- Voltage Range 104 - 127V

### SERVICE

- Panels easily removed and all components accessible for service.
- Removable/cleanable air filters. (Air-cooled models only)

